

Automated Canning Process Control Appliance (using ramp/soak temperature controller)

- Cut List: White Pine 12 x 6ft x 3/4 (2 pcs.)**
1. Sides: 10 3/4 x 17 1/2 x 3/4 (2 pcs.)
 2. Back: 14 1/2 x 6 x 3/4 (2 pcs.)
 3. Bottom: 18 x 15 1/4 x 3/4
 4. Blocks: 1 3/4 x 2 x 3/4 (4 pcs.)
- Bottom is made from edge-glued 2 pcs. 18 x 7.625 x 3/4

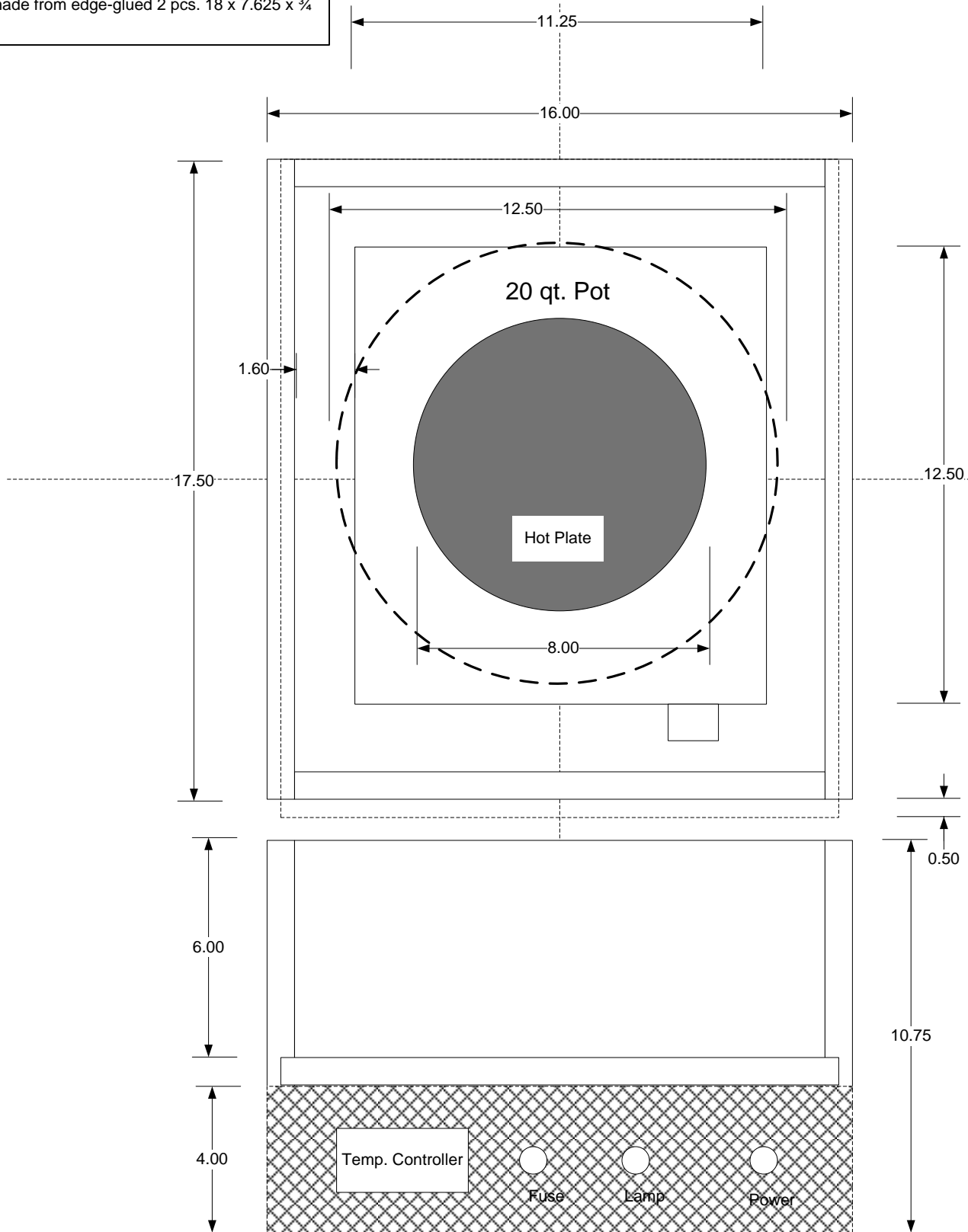

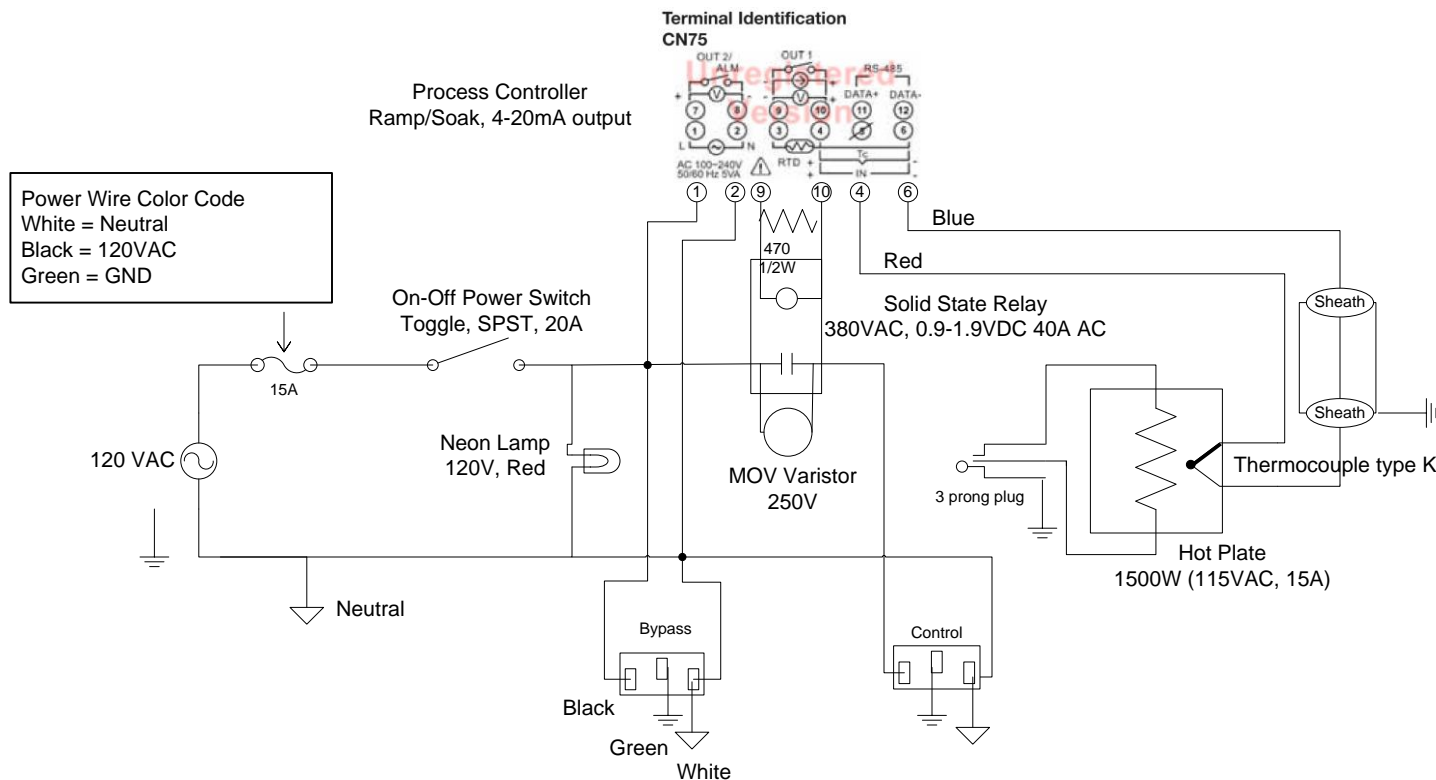

Electrical Parts List

1. Omega CN7453 Process Controller
2. Cadco 1500W Hot Plate
3. SSR 380V
4. Neon Lamp 120V Red
5. Thermocouple Type K
6. MOV Varistor 240V
7. Dual 120v, 20A outlet, Leviton model CB20A
8. Capacitor 47uF, 35V
9. Resistor 470 ohm, 1/2W (1/4W OK)
- 10.

Food Canning Automated Processing Appliance				
IPG-0000-ABC-001.9				
SIZE	FSCM NO	DWG NO	REV	
		IPG-0000-ABC-001.9	0.9	
SCALE	1/4 : 1	IPGENERAL	SHEET	2 OF 9

Supply piece 1



Supply piece 2

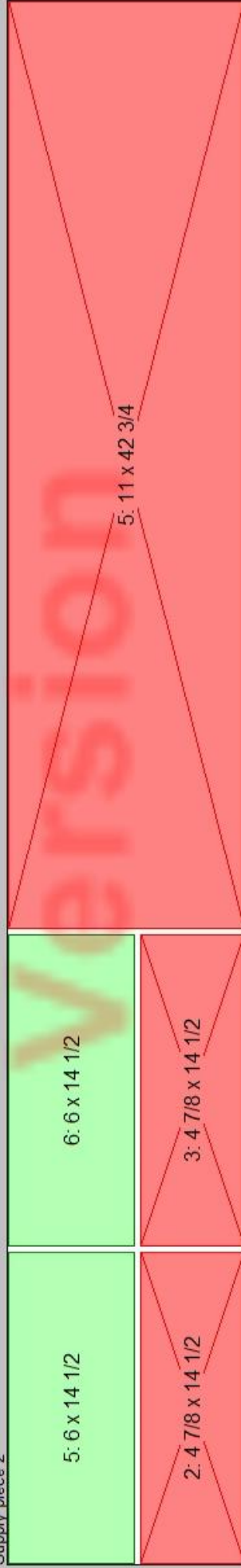

Regulation **Operation**

Pidn=4 (Auto Reg.)

HhS = 1F
ChS = 1F

SP = 0 decimal point

AL-1H = 200F
AL-1L = N/A in Heat only mode

dEAd = 2F
(only available in PID control)

Initial

K
F
210F
40F
ON/OFF or ProG
HEAT
6 = Absolute Temp. Upper Limit
ALA2 Doesn't Exist
ALA3 Doesn't Exist
SALA = 0 (off)

Regulation Mode	Operation Mode	Initial Setting Mode
00.00 Auto-tuning (Set in PID control & RUN mode) Press ↵ to set temperature	00.00 Use ▲ ▼ to set temperature set point Press ↵	00.00 Set input type Press ↵
00.00 4 groups PID modes (n=0-3). When n=4, PID control is auto regulated. Press ↵	00.00 Control setting RUN or STOP Press ↵	00.00 Set temperature unit (Not displayed when in analog input) Press ↵
See PID Control section.	See "Execution" in Section 6	00.00 Set upper-limit of temperature range Press ↵
00.00 PID control offset (when PID control is ON and TIn0, set the value of PdoF). Press ↵	00.00 start pattern setting. Appears only when 00.00 is set to 00.00 . Press ↵	00.00 Set lower-limit of temperature range Press ↵
00.00 Heating hysteresis (in ON/OFF control) Press ↵	00.00 Set the position of decimal point (Not for thermocouple R, S, B type) Press ↵	00.00 Set Control method: ON/OFF, PID, Prog. or manual. (Set to ProG for ramp/soak patterns) See 6. Pattern and Set editing. Press ↵
00.00 Cooling hysteresis (in ON/OFF control) Press ↵	00.00 Upper-limit alarm 1 (This parameter is available only when ALA1 function is enabled.) Press ↵	00.00 Ramp/soak pattern. Only displayed when Ctrl. is set to ProG. Press ↵
00.00 or 00.00 Heating/cooling control cycle setting (Set in PID control mode) Press ↵	00.00 Lower-limit alarm 1 (This parameter is available only when ALA1 function is enabled.) Press ↵	00.00 Select heating, cooling control or dual loop output control. Press ↵
00.00 Control cycle setting of 2 nd output group (Set in PID control and dual loop output control mode) Press ↵	00.00 Upper-limit alarm 2 (This parameter is available only when ALA2 function is enabled.) Press ↵	00.00 Alarm 1 mode setting Press ↵
00.00 Ratio of output 1 & output 2 when in dual output control. P value of 2 nd output group = (P value of 1 st output group) (Set it up when in PID/programmable PID + dual output) = 00.00 Press ↵	00.00 Lower-limit alarm 2 (This parameter is available only when ALA2 function is enabled.) Press ↵	00.00 Alarm 2 mode setting Press ↵
00.00 Dead Band (set in dual loop output control mode) Press ↵	00.00 Upper-limit alarm 3 (This parameter is available only when ALA3 function is enabled.) Press ↵	00.00 Alarm 3 mode setting Press ↵
00.00 Regulate temperature deviation value Press ↵	00.00 Lower-limit alarm 3 (This parameter is available only when ALA3 function is enabled.) Press ↵	00.00 Set system alarm Press ↵
00.00 Regulate upper-limit of analog output value (The setting is displayed when in analog output) Press ↵	00.00 Set lock mode Press ↵	00.00 Communication write function enabled/disabled Press ↵
00.00 Regulate lower-limit of analog output value (The setting is displayed when in analog output) Press ↵ to return to "auto-tuning"	00.00 Display and adjust output value of 1 st output group (Displayed when in PID control mode and manual RUN mode) Press ↵	00.00 Select ASCII/RTU communication format Press ↵
	00.00 Display and adjust output value of 2 nd output group (Displayed when in dual loop PID control mode and manual RUN mode) Press ↵	

Operational Programming

6 Pattern and Set Editing (Ramp and Soak Programming)

Description of Function and Parameters Setting:

To set-up or edit the ramp/soak function, **00.00** in the initial setting mode must be set to **00.00**, **00.00**. Will immediately follow in the menu list.

The Ramp and Soak function is supported by 8 different patterns (Pattern No. 0 ~ 7). Each pattern contains 8 steps (step No. 0 ~ 7) for set point and execution time, one Link Pattern parameter, one Cycle parameter and one Actual Step parameter. The set point (SV) should reach temperature X after the execution time T. The default of step No. 0 is soak control. The unit will control the temperature (PV) to reach the set point X and then keep the temperature at set point X. The execution time T is determined by step No. 0.

The following display is an example of operation of pattern No. 0. **00.00** Patn where n = 0-7.

00.00 Select desired editing pattern number Select OFF Press ↵ 00.00 select number	00.00 Edit temperature of step No.0 of pattern No.0 Press ↵	00.00 Select actual step No. when program control is executing Press ↵
Exit pattern and step editing selection Switch to 00.00 and continue setting	00.00 Edit time of step No.0 of pattern No.0. Unit: hh:mm Press ↵	00.00 Set additional execution cycle number (0-99) Press ↵
	Set step No.1-7 in order 00.00 Edit temperature of step No.7 of pattern No.0 Press ↵	00.00 Set link pattern. OFF indicates the program end Press ↵ to return to pattern No. editing mode
	00.00 Edit time of step No.7 of pattern No.0. Unit: hh:mm Press ↵ to set actual step No.	

Actual Step Parameter **00.00**: Offered for each pattern (0-7), the user can select to execute only certain steps in the pattern. For example, when **00.00** is set to 2, pattern No 7 will only execute steps 0 through 2.

Cycle Parameter **00.00**: Offered for each pattern (0-7), the cycle parameter will execute the selected pattern X amount of times. For example, when **00.00** is set to 2, pattern No. 4 will cycle through the steps and then cycle through the steps 2 more times.

Link Pattern Parameter **00.00**: Offered for each pattern (0-7), the link parameter designates the next pattern to execute. For example, when **00.00** is set to 2, pattern No. 2 will execute next after the execution of pattern No. 0. If **00.00** is set to **00.00**, the program will stop after executing the current pattern and the temperature will be maintained at the set point of the last step.

Execution:

The execution of the ramp and soak function is initiated through **00.00** in the operation mode.

When **00.00** is set to **00.00**, the program will start to execute in order from the step 0 of the start pattern.

When **00.00** is set to **00.00**, the program will stop and the control output is disabled.

When **00.00** is set to **00.00**, the program will stop and the temperature will be maintained at the set point before program was stopped. Select **00.00** again, then the program will restart and execute from step 0 of start pattern. The start pattern setting **00.00** is accessed when **00.00** is set to **00.00** and the INDEX key **↵** is pressed. (The start pattern setting only appears in **00.00** mode).

When **00.00** is set to **00.00**, the program will hold and the temperature at that time will be controlled at the set point before program hold. Select **00.00** again, then the program will follow the step before hold and start to execute through the rest of the time.

Display: During ramp and soak program control, the SV default display is P-XX, P indicates the current execution pattern and XX indicates the current execution step. Press **▲** **▼** to change the SV display item to set point value **00.00** or residual time **00.00**.

After selecting **00.00**, press **↵** key, and then the temperature set point of the current execution step will display on SV display.

After selecting **00.00**, press **↵** key, and then the residual time of the current execution step will display on SV display.

Dual Outlet Cutout

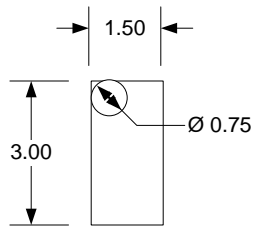

Leviton 20A #CBR20

Danger: If feedback temperature sensor (thermocouple) malfunctions or becomes separated from process contents, temperature control may enter an unregulated state including CONTINUOUS FULL POWER HEATING.

To mitigate these circumstances, set Hot Plate temperature control to a minimum (safe) power level.

Operating Instructions:

Appliance operates in 3 modes

1. Bypass: Use ***Bypass*** electrical outlet, process temperature is controlled by Hot Plate power setting only.
2. Constant Temp: Use ***Control*** electrical outlet, process is controlled at a constant temperature for as long as power is applied.
3. Ramp/Soak: Use ***Control*** electrical outlet, process temperature is controlled by a programmed time sequence.

To start Constant Temp process:

1. Turn Power Switch On
2. Hold Enter button for 3 seconds
3. Index to Ctrl, Set Ctrl to ON/OFF. Press Enter
4. Set process temperature (SV) using Up/Down controls. Press Enter

To start Ramp/Soak program:

1. Turn Power Switch On
2. Hold Enter button for 3 seconds
3. Index to Ctrl, Set Ctrl to ProG. Press Enter
4. Press Index button once
5. Use Up/Down controls to set r-S = rUn. Press Enter
(Display shows Process Value (PV) temperature and pattern# step#)

Control

Bypass

FUSE: 15A

MAIN POWER

Ramp/Soak Test Example Process & Program

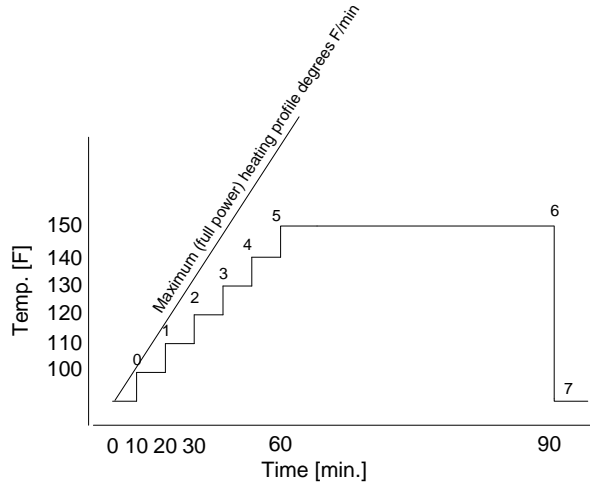

Pattern 0: (example)

```
SP00 = 100F, ht00 = 00:10  
SP01 = 110F, ht02 = 00:10  
SP02 = 120F, ht03 = 00:10  
SP03 = 130F, ht04 = 00:10  
SP04 = 140F, ht05 = 00:10  
SP05 = 150F, ht06 = 00:10  
SP06 = 150F, ht03 = 00:30 (soak)  
SP07 = 40F, lt07 = OFF (end program)
```

1. Enter Initial Mode – press Enter for 3 seconds
2. Index to Ctrl
3. Use Up/Down Control, set Ctrl = ProG, press Enter
4. Index to Patn
5. use Up/Down controls to select pattern# (0-7), press Enter
6. Index to SPxy (where x is pattern# (0-7), y is step# (0-7))
7. Use Up/Down controls to enter Temperature (SV), press Enter
8. Index to htxy (where x is pattern# (0-7), y is step# (0-7))
9. Use Up/Down controls to set step time (HH:mm), press Enter
10. Continue entering Temperature and Time values for all 8 steps
11. Index to lt07
12. Use Up/Down controls to set lt07 = oFF to (maintain step 7 temp.), press Enter

Misc. Ramp/Soak parameters:

PsY0 = 7 (0-7) (Pattern n 0-7, set Last pattern step#)

CyC0 = 0 (0-99) (repeat Pattern)



M4437A.pdf



M4437.pdf



M4704.pdf

